

Dräger Babylog® VN800 Neonatal Intensive Care Ventilation

Babylog® VN800 comes with a new user interface and design which makes operation easier and more efficient. The neonatal ventilator supports lung and brain protective ventilation modes throughout the whole respiratory cycle and can be easily integrated in a developmental care friendly workplace.



Benefits

Operation principle and user interface

The brilliant user interface combined with a timely glass touch technology supports intuitive operation and lowers education times and possible errors.

- Quick and safe to operate even in the most stressful situations due to intuitive menu access to both settings and your clinical data.
- All patient data, alarms and trends are fully recorded. Conveniently exported via USB interface.
- Switch between multiple view configurations with the touch of a finger.
- Step-by-step guidance leads you through every procedure.
- Easy to read and navigate thanks to our new colour concept and glass touch display.
- The 360° alarm light flashes in the color of the corresponding alarm priority and is visible from every direction.

Lung and brain protective ventilation

Our set of treatment tools supports you in applying the right protective lung and brain ventilation strategy in order to prevent lung injury, haemodynamic and neurological impairment.

- Dedicated invasive and non-invasive ventilation capabilities including high-flow oxygen therapy
- Lung and brain protective ventilation due to automated pressure regulation with the original Dräger Volume Guarantee
- Lung and brain protective ventilation due to High Frequency Ventilation with Volume Guarantee (HFO-VG)
- Stable minute ventilation and protective weaning with Mandatory Minute Ventilation (PC-MMV/VG+PS)
- Maintain reliable and sensitive triggering and stable lung tidal volumes with original Dräger leak adaptation and leak compensation technology
- Proportional support for compensation of ETT resistances

Care-centered workplaces

From delivery to discharge: As your specialist in acute care, we want to accompany you through your clinical patient pathway and enable a developmental care- friendly environment to support all of the complex needs of the developing lung, brain and other organs. We do this through our wide range of products and solutions for L&D, transportation, and the NICU. Our products:

- are compatible with each other and work with the same Dräger operating philosophy
- give you a flexible workplace integration with different cockpit sizes and mounting possibilities
- offer low operational noise levels even during High Frequency Ventilation or non-invasive ventilation to provide a silent environment for the baby, the parents and for NICU staff
- provide you with effective infection prevention thanks to easy cleaning of the glass touch screen and other smooth surfaces
- come with longer circuits and cables which allow staff and parents to remove the baby from the incubator for kangaroo time without compromising the baby's ventilation

Benefits

- include a broad range of Dräger accessories with optimised circuits for High Frequency Ventilation and non-invasive interface Babyflow Plus
- support patient transport with external and internal power supply, bed coupling for incubator or bed and transport supply unit

Connectivity

We envision a future of acute care where medical devices are connected as a system. Interoperability between different devices can help to avoid preventable medical errors and potentially serious inefficiencies. The new standardised network protocol named SDC makes the safe and dynamic connectivity in the hospital possible which will allow interoperability of medical devices in the future.

Our first step will be connectivity through CC300:

- Full HL7 data export to HIS: reliability exchange high-quality data in a standardised format between medical devices and EMR.
- Future-proof open connectivity: standardised and secure communication between medical devices with a high level of cyber security.

Comprehensive Services

Our comprehensive consulting and support services ensure maximum performance in more fields than you would expect.

- Product service such as inspection and device maintenance to ensure a maximum uptime
- Professional service like IT consulting and system integration
- Online and class-room trainings
- Multivendor service
- Digital services like network-based services and analysis of device data
- Access to online neonatal community BabyFirst community for clinicians and parents of premature babies. Visit www.babyfirst.com.

Awards



Physical Specifications

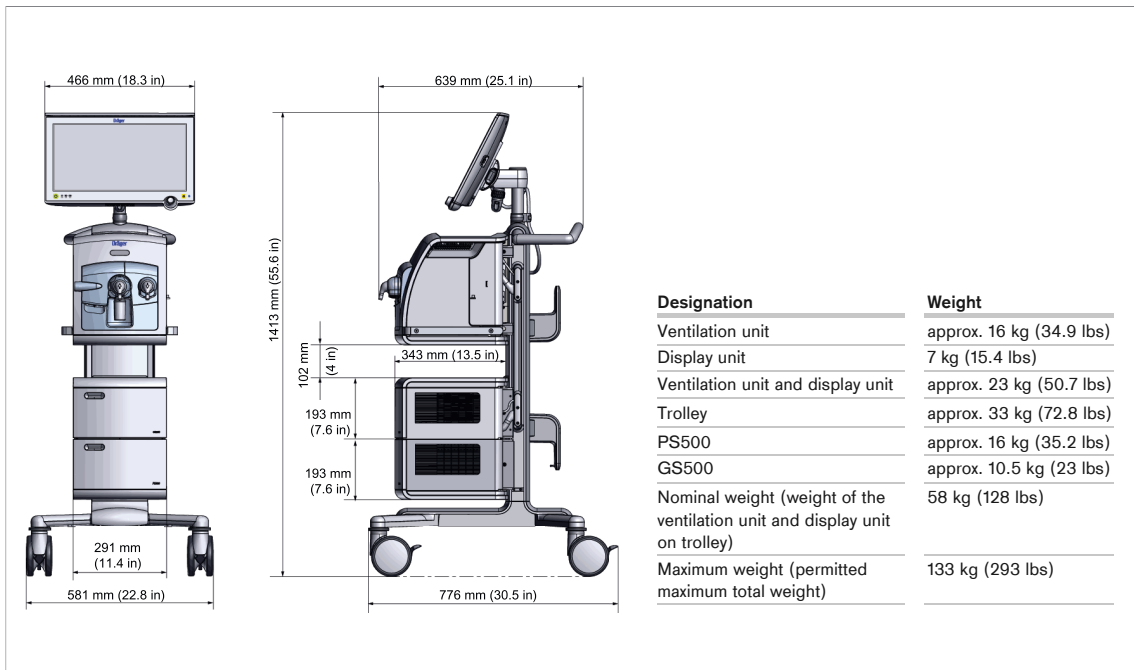

Dimensions and weights of the Babylog VN800

Accessories

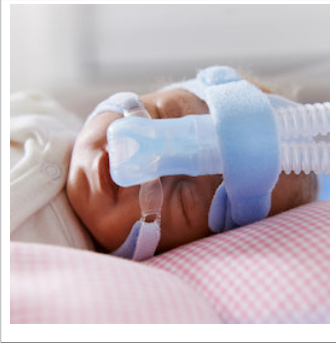

NeoAcc

Neonatal Ventilation Accessories

Dräger original neonatal ventilation accessories are suitable for different ventilation strategies and have an optimised length (e.g for strong HFOV and with long circuits for kangaroo care), pressure transmission and humidification performance. Our accessories work with full compatibility with our neonatal ventilator Babylog. Find them all in our neonatal accessories catalogue.

Related Products



D-43871-2015

Dräger Babyleo® TN500

The Babyleo® TN500 is Dräger's first IncuWarmer that provides optimal thermoregulation for neonates in open care, closed care and transition. With the combination of three heat sources, this device protects your little patients so they can grow while making your workflow easier with quick and comfortable access to the baby.



D-7286-2016

Isolette® 8000 plus

Dräger sets the standard for thermoregulation with a host of performance features designed to provide a stable, cocoon-like environment for the baby. To ensure that the Thermo-Neutral Zone is maintained, the Isolette® 8000 plus enables you to continuously monitor both the central and peripheral body temperature.

Related Products



D-86396-2013

Dräger Jaundice Meter JM-105

The Dräger Jaundice Meter JM-105 gives you consistent quality screening, cost-effectively delivered over the lifetime of the device. As a result you optimize the efficiency of your jaundice management program, which can help save time and money while delivering an exceptional standard of care.



D-12195-2016

BiliLux

The BiliLux is a compact and lightweight LED phototherapy light system for the treatment of neonatal unconjugated hyperbilirubinemia. It provides superior phototherapy performance, individualised therapy with electronic documentation capabilities and the flexibility for seamless integration into practically every workplace.



D-15228-2017

Seattle PAP plus – Bubble CPAP System

Helping infants with respiratory distress breathe easier.³
The Seattle-Positive Airway Pressure (PAP) system is an innovation which uses the proven advantages of Bubble CPAP therapy, such as oscillatory effects similar to high frequency ventilation^{1, 2} combined with a unique design.

Technical Data

Patient type	Paediatric patients, neonates
Ventilation settings	
Ventilation mode	Pressure controlled ventilation: <ul style="list-style-type: none"> - PC-CMV - PC-SIMV - PC-AC - PC-APRV - PC-PSV - PC-HFO - PC-MMV Support of spontaneous breathing: <ul style="list-style-type: none"> - SPN-CPAP/PS - SPN-CPAP/VS - SPN-CPAP - SPN-PPS
Enhancements	<ul style="list-style-type: none"> - Volume Guarantee/HF-Volume Guarantee - Smart Pulmonary View - Automatic Tube Compensation (ATC®) - APRV-AutoRelease® - Apnoea ventilation - Automatic flow adjustment
Special procedures	<ul style="list-style-type: none"> - Suction manoeuvre - Manual inspiration/hold - Medication nebulisation
Therapy types	<ul style="list-style-type: none"> - Invasive ventilation (Tube tracheostomy) - Non-invasive ventilation (NIV) - O₂-therapy
Respiratory rate (RR)	Paediatric patients, Neonates 0.5 to 150/min
Inspiratory time (Ti)	Paediatric patients, Neonates 0.1 to 3 s
Maximum inspiratory time for supported breaths (T _{imax})	Paediatric patients 0.1 to 4 s Neonates 0.1 to 1.5 s
Tidal volume (VT)	Paediatric patients 20 to 300 mL Neonates 2 to 100 mL
Inspiratory flow (Flow)	Paediatric patients, Neonates 2 to 30 L/min
Maximum flow during non-invasive ventilation of neonates (Flow max)	0 to 30 L/min
Respiratory rate during apnea ventilation (RR _{apn})	2 to 150 min
Inspiratory pressure (P _{insp})	1 to 80 mbar (or hPa or cmH ₂ O)
Pressure limitation (P _{max})	2 to 100 mbar (or hPa or cmH ₂ O)
Positive end-expiratory pressure (PEEP)	0 to 35 mbar (or hPa or cmH ₂ O)
Pressure rise time (Slope)	Paediatric patients 0 to 2 s Neonates 0 to 1.5 s
O ₂ concentration (FI _{O2})	21 to 100 Vol. %
Trigger threshold (Trigger)	0.2 to 5 L/min
Pressure support (P _{supp})	0 to 80 mbar (or hPa or cmH ₂ O)
Automatic Tube Compensation (ATC®)	Inner diameter of the tube Ø

Technical Data

	<ul style="list-style-type: none"> - Endotracheal tube Paediatric patients 2 to 8 mm (0.08 to 0.31 inch) Neonates 2 to 5 mm (0.08 to 0.2 inch) - Tracheostomy tube Paediatric patients 2.5 to 8 mm (0.1 to 0.31 inch) - Degree of tube compensation 0 to 100 %
High Frequency Oscillation (PC-HFO)	<ul style="list-style-type: none"> - Mean airway pressure (MAPhf) 5 to 50 mbar (or hPA or cmH₂O) - Frequency of oscillation (fhf) 5 to 20 Hz - I to E (I:Ehf) 1:1 to 1:3 - Pressure amplitude (Ampl hf) 5 to 90 mbar (or hPA or cmH₂O) - Maximum pressure amplitude (Ampl hf max) in HFO (VG) 5 to 90 mbar (or hPA or cmH₂O) - Tidal volume (VThf) 0.2 to 40 mL - Sigh pressure (Psigh) 6 to 80 mbar (or hPA or cmH₂O) - Respiratory rate of sigh (RRsigh) 0 to 30/min - Sigh pressure rise time (Slope sigh) Pediatric patients 0 to 2 s, Neonates 0 to 1.5 s - Sigh inspiratory time (Tisigh) 0.1 to 3 s
Leakage compensation	<ul style="list-style-type: none"> - On, off - On: complete compensation active - Off: only trigger compensation active
O ₂ -therapy	Continuous Flow 2 to 50 L/min O ₂ concentration FiO ₂ 21 to 100 Vol%
Displayed measured values	
Airway pressure measurement	Positive end-expiratory pressure (PEEP) Peak Inspiratory Pressure (PIP) Mean airway pressure (Pmean) Minimum airway pressure (Pmin) Lower pressure level in APRV (Plow) End-inspiratory pressure for mandatory breaths (EIP) Upper pressure level in APRV (Phigh) Range -60 to 120 mbar (or hPa or cmH ₂ O)
Flow Measurement (proximal)	
Minute volume measurement	Expiratory minute volume, overall, not leakage-corrected (MVe) Inspiratory minute volume, overall, not leakage-corrected (MVi) Minute volume, leakage-corrected (MV) Mandatory expiratory minute volume, overall, not leakage-corrected (MVemand) Spontaneous expiratory minute volume, overall, not leakage-corrected (MVespon) Range 0 to 30 L/min, BTPS
Tidal volume measurement	Tidal Volume, leakage-corrected (VT)

Technical Data

Performance data

Control principle	Time-cycled, volume-constant, pressure-controlled
Length of intermittent PEEP	1 to 20 expiratory cycles
Medication nebulisation	For 5, 10, 15, 30 minutes, continuously (∞)
Inspiratory flow	Paediatrics Max. 60 L/min, BTPS Neonates Max. 30 L/min, BTPS
Base flow, paediatric patients	3 L/min
Base flow, neonates	6 L/min
Base flow during active pneumatic nebulisation, paediatric patients	6 L/min
Inspiratory valve	Opens if the compressed air supply fails (supply gas flow is not sufficient to provide the inspiratory flow required), enables spontaneous breathing with ambient air.

Endotracheal suction

Disconnection detected	Automatic
Reconnection detected	Automatic
Preoxygenation	Max. 3 minutes
Active suction phase	Max. 2 minutes
Postoxygenation	Max. 2 minutes
Factor for paediatric patients and neonates	1 to 2
Supply system for spontaneous breathing and P _{supp}	Adaptive CPAP system with high initial flow

Operating data

Mains power supply

Electric power inlet	100 V to 240 V, 50/60 Hz
----------------------	--------------------------

Current consumption

At 230 V	Max. 1.3 A
At 100 V	Max. 3.0 A
Inrush current	Approx. 8 to 24 A peak Approx. 6 to 17 A quasi-RMS

Power consumption

Maximum	300 W
During ventilation, without charging the battery	Approx. 100 W ventilation unit with display unit Approx. 180 W with GS500

Gas supply

O ₂ positive operating pressure	2.7 to 6.0 bar (or 270 to 600 kPa or 39 to 87 psi)
Air operating pressure	2.7 to 6.0 bar (or 270 to 600 kPa or 39 to 87 psi)

Battery details

Internal battery of ventilation unit (without PS500)	Type NiMH battery, sealed
Battery runtime if mains power supply is not available	Without GS500 30 minutes With GS500 15 minutes
Batteries in the PS500 power supply unit	Type LFP batteries
Battery runtime if mains power supply is not available	Without GS500 240 minutes With GS500 120 minutes

Automatic switch over from internal to external

Battery test available

The battery runtime applies when the batteries are fully charged and new and ventilation is typical.

Technical Data

Screen values

Babylog VN800 diagonal screen size	18.3 inches
Input / Output ports	<ul style="list-style-type: none"> - 3 external RS232 (9-pin) connectors - 4 USB ports for data collection - 1 LAN port
Touchscreen technology	Capacitive touchscreen with glass front
Aspect ratio	16:9
Resolution	1366 x 768 pixels
Digital machine output	Digital output and input via an RS232 C interface Dräger MEDIBUS®, MEDIBUS® comp. and MEDIBUS®.X

¹ Mechanisms of gas transport during ventilation by high frequency oscillation. J Appl Physiol 1984;56(3):553-563, Chang HK.

² High-Frequency Oscillatory Ventilation: Theory and Practical Applications, Jane Pillow, Dräger Booklet 9102693 from 2016

³ Short term evaluation of respiratory effort by premature infants supported with bubble nasal continuous airway pressure using Seattle-PAP and a standard bubble device. PLOS ONE, March 28, 2018, Stephen E. Welty, Craig G. Rusin, Larissa I. Stanberry, George T. Mandy, Alfred L. Gest, Jeremy M. Ford, Carl H. Backes, Jr, C. Peter Richardson, Christopher R. Howard, Thomas N. Hansen, Charles V. Smith

BTPS – Body Temperature Pressure Saturated. Measured values relating to the conditions of the patient lung 37° C (98.6° F), steam-saturated gas, ambient pressure.

1 mbar = 100 Pa

Some functionalities are available as an option.

Notes

Not all products, features, or services are for sale in all countries.
Mentioned Trademarks are only registered in certain countries and not necessarily in the country in which this material is released. Go to www.draeger.com/trademarks to find the current status.

CORPORATE HEADQUARTERS

Drägerwerk AG & Co. KGaA
Moislinger Allee 53–55
23558 Lübeck, Germany
www.draeger.com

Manufacturer:

Drägerwerk AG & Co. KGaA
Moislinger Allee 53-55
23542 Lübeck, Germany

REGION EUROPE

Drägerwerk AG & Co. KGaA
Moislinger Allee 53–55
23558 Lübeck, Germany
Tel +49 451 882 0
Fax +49 451 882 2080
info@draeger.com

REGION MIDDLE EAST, AFRICA

Drägerwerk AG & Co. KGaA
Branch Office
P.O. Box 505108
Dubai, United Arab Emirates
Tel +971 4 4294 600
Fax +971 4 4294 699
contactuae@draeger.com

REGION ASIA PACIFIC

Draeger Singapore Pte. Ltd.
61 Science Park Road
The Galen #04-01
Singapore 117525
Tel: +65 6872 9288
Fax: +65 6259 0398
asia.pacific@draeger.com

REGION CENTRAL AND SOUTH AMERICA

Dräger Indústria e Comércio Ltda.
Al. Pucurui - 51 - Tamboré
06460-100 - Barueri - São Paulo
Tel. +55 (11) 4689-4900
relacionamento@draeger.com
Panamá Comercial

Locate your Regional Sales
Representative at:
www.draeger.com/contact

